

400 / 450 / 630 / 1000 / 1250 / 1600 / 2000 kg

4 bis 26 Personen - 4 to 26 persons

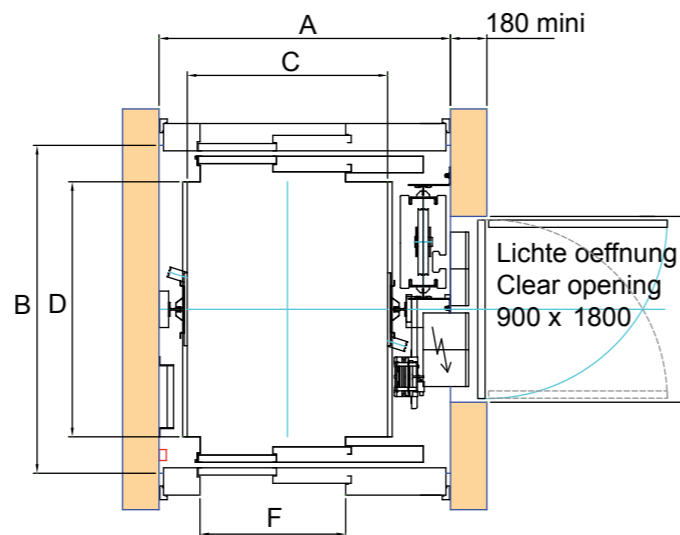

Zuganür / Access door
1020 X 1900

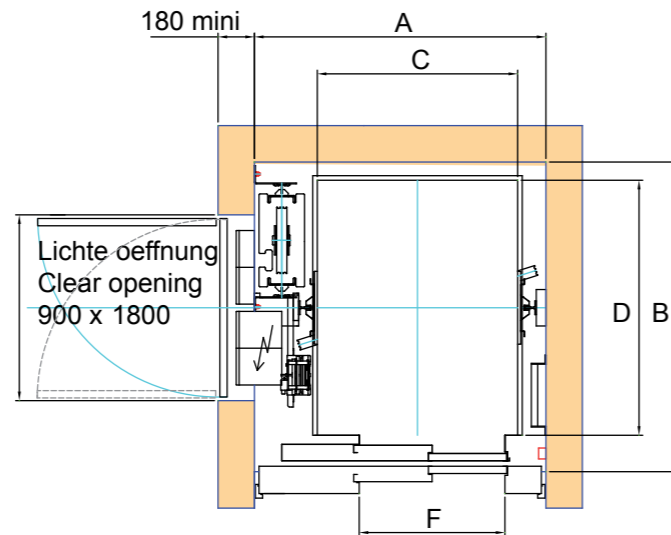
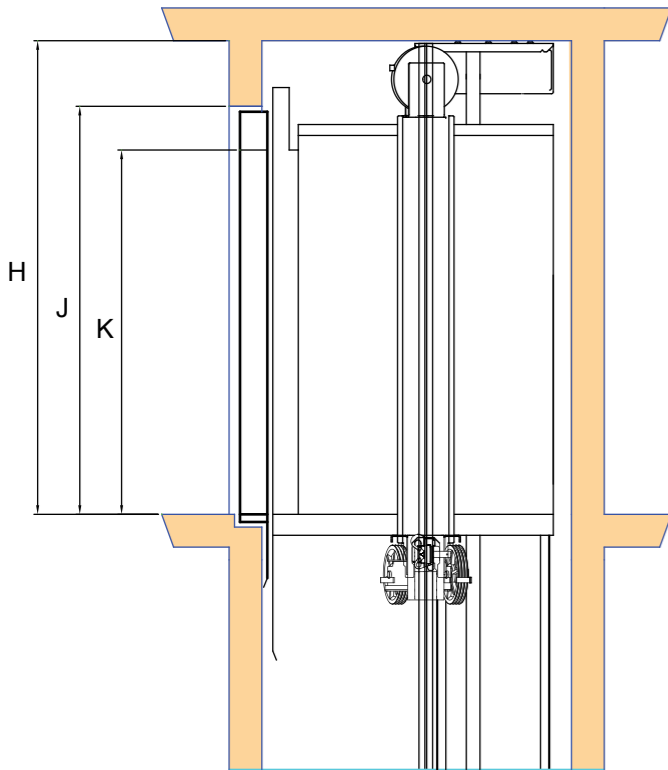
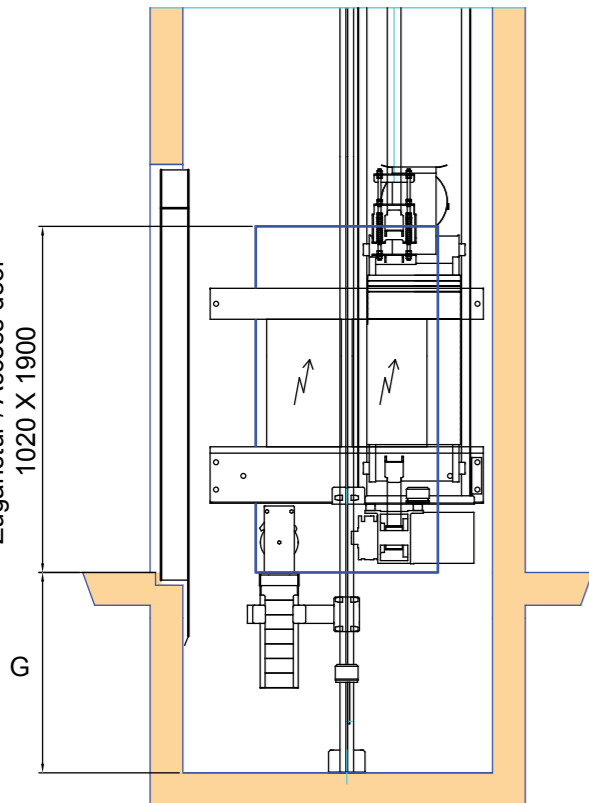

Bewegliche Last Load (kg)	Pers.	Fläche Surface (m²)	Offnung Opening			Schacht Shaft		Kabine Car						
			Zugang Access	Typ Type	Lichte oeffnung Clear opening F	Breite Width A	Tiefe Depth B	Breite Width C	Tiefe Depth D					
400	5	1,17	Einfach Simple	Telesk. Telescopic	800	1500	1500	1000	1100					
450	6	1,3	Einfach Simple	Telesk. Telescopic	800	1500	1550	1000	1250					
630	8	1,66	Einfach Simple	Telesk. Telescopic	800	1600	1700	1100	1400					
					900									
					900									
			Doppelt Double	Telesk. Telescopic	800	1600	1800							
					900									
					900									
Doppelt Double	Centrale Central	800	1800	1750										
		900												
		900												
1000	13	2,4	Einfach Simple	Telesk. Telescopic	800	1600	2400	1100	2100					
					900									
					900									
			Doppelt Double	Telesk. Telescopic	800	1600	2500							
					900									
					900									
Doppelt Double	Centrale Central	800	1800	2450										
		900												
		900												
1275	17	2,95	Einfach Simple	Telesk. 2B Telescopic 2P	900 (A mini 1600) 1100 (A mini 1950)	1600	Mini	Maxi	Mini	Maxi	Mini	Maxi	Mini	Maxi
							2600	1900	2900	1100	2100	1200	2600	
1600	21	3,56	Einfach Simple	Telesk. 2B Telescopic 2P	1100 (A mini 1950)	2150	Mini	Maxi	Mini	Maxi	Mini	Maxi	Mini	Maxi
							2850	2100	3200	1400	2100	2000	2900	
2000	26	5	Einfach Simple	Telesk. 2B Telescopic 2P	1100 (A mini 1950)	2150	Mini	Maxi	Mini	Maxi	Mini	Maxi	Mini	Maxi
							2600	2600	3300	1400	1850	2200	2900	

Bewegliche Last Load (kg)	Geschwindigkeit Speed m/s	Grube Pit G	Ankunftshöhe Headroom H	
			K = 2000 J = 2240	K = 2100 J = 2340
400	1	1100	2600	2700
450	1,6	1350	3200	3300
630				
800	1	1150	2600	2700
1000	1,6	1400	3200	3300
1275	1	1150	3000	3100
	1,6	1400	3600	3700
1600	1	1450	3600	3700
2000				

Für die anderen Dimensionen, uns zu befragen
Contact us for all others dimensions

Dimensionen
Dimensions (mm)